



ICC Evaluation Service, Inc.
www.icc-es.org

Business/Regional Office ■ 5360 Workman Mill Road, Whittier, California 90601 ■ (562) 699-0543
Regional Office ■ 900 Montclair Road, Suite A, Birmingham, Alabama 35213 ■ (205) 599-9800
Regional Office ■ 4051 West Flossmoor Road, Country Club Hills, Illinois 60478 ■ (708) 799-2305

Legacy report on the BOCA® National Building Code/1999 and the 1998 International One- and Two-Family Dwelling Code®

DIVISION: 06—WOOD AND PLASTICS
Section: 06090—Wood and Plastic Fastenings

REPORT HOLDER:

METWOOD, INC.
819 NAFF ROAD
BOONES MILL, VIRGINIA 24065
(540) 334-4294
www.metwood.com

EVALUATION SUBJECT:

METWOOD 2×10 JOIST REINFORCER

EVALUATION SCOPE

Compliance with the following codes:

- BOCA® National Building Code/1999
 - Section 106.4 Alternative materials and equipment
 - Section 2305.3 Cutting and notching
 - Section 2305.3.1 Solid lumber joists
- 1998 International One- and Two-Family Dwelling Code®
 - Section 108.1 Alternative materials, methods, and equipment
 - Section 502.6 Drilling and notching
 - Section 502.6.1 Sawn lumber

DESCRIPTION

The Metwood 2×10 Joist Reinforcer is a steel plate bracket with fasteners that allows for holes larger than those allowed by the applicable code to be used on nominal 2×10 solid sawn No. 2 Southern pine lumber joists. The Metwood 2×10 Joist Reinforcer is fabricated from 18 gauge steel with a yield strength (Fy) of 50 ksi conforming ASTM A 446, to allow for a 6-inch-diameter (51 mm) hole located in the center of the joist depth. See Figure 1 of this report for a diagram of, and installation requirements for, the Metwood 2×10 Joist Reinforcer.

CONDITIONS OF USE

This report is limited to the applications and products as stated in this report. The ICC-ES Subcommittee on National Codes intends that the report be used by the code official to determine that the report subject complies with the code requirements specifically addressed, provided that this product is installed in accordance with the following conditions:

- The Metwood 2×10 Joist Reinforcer shall be installed in accordance with this report.

- The Metwood 2×10 Joist Reinforcer shall be limited to use with nominal 2×10 solid sawn No. 2 Southern pine lumber joists with a maximum span of 15 feet (4570 mm).
- A maximum of one Metwood 2×10 Joist Reinforcer shall be used along the span of the joist.
- Holes in the joists, other than the Metwood 2×10 Joist Reinforcer, shall be limited to a maximum size of 1½-inch-diameter (38 mm), and shall be no closer than 20 inches (508 mm) from either outside edge of the Metwood 2×10 Joist Reinforcer.
- The application of the Metwood 2×10 Joist Reinforcer is limited to covered, dry conditions of use. Dry conditions of use are those conditions at which the moisture content for solid-sawn lumber is less than 16 percent.
- Use of the Metwood 2×10 Joist Reinforcer with preservative treated lumber is outside the scope of this report.
- The Metwood 2×10 Joist Reinforcer shall not be located closer than 12 inches (305 mm) from the closest support.
- This report is subject to periodic re-examination. For information on the current status of this report, contact the ICC-ES.

APPLICATION FOR PERMIT

To aid in the determination of compliance with this report, the following represents the minimum level of information to accompany the application for permit:

- The language “See ICC-ES Legacy Report No. 97-73” or a copy of this report;
- Construction documents indicating compliance with this report. The following items shall be clearly shown on the construction documents:
 - Location and quantity of the Metwood 2×10 Joist Reinforcer, consistent with this report.
 - Species, Grade, nominal cross-sectional size, and span of the solid sawn lumber joists used with the Metwood 2×10 Joist Reinforcer, consistent with this report.
 - Design calculations and details verifying the ability of the building structure, in which the Metwood 2×10 Joist Reinforcer is used, to carry all superimposed loads as required by Chapter 16 of the BOCA® National Building Code/1999. These documents shall be prepared by an individual competent and qualified in the application of the structural design principles involved. The individual shall possess the registration or license in accordance with the professional registration laws of the state in which the project is constructed.

ICC-ES legacy reports are not to be construed as representing aesthetics or any other attributes not specifically addressed, nor are they to be construed as an endorsement of the subject of the report or a recommendation for its use. There is no warranty by ICC Evaluation Service, Inc., express or implied, as to any finding or other matter in this report, or as to any product covered by the report.

ITEMS REQUIRING VERIFICATION

The following items are related to the use of the report subject, but are not within the scope of this evaluation. However, these items are related to the determination of code compliance:

- U Details, notes and calculations for the design and construction of the building structure in which the Metwood 2×10 Joist Reinforcer is used, as required by the BOCA® *National Building Code/1999*, prepared by a qualified individual as indicated in this report.

INFORMATION SUBMITTED

- Report to Metwood Incorporated, prepared and signed by Dr. Joseph R. Loferski, dated July 20, 2000, containing physical testing and statistical analysis. The physical testing compared the maximum strengths and modulus of elasticity of nominal 2×10 solid sawn No. 2 Southern pine lumber joists, at a 15 foot span, with and without the Metwood 2×10 Joist Reinforcer installed. The joists without the Metwood 2×10 Joist

Reinforcer installed were tested without holes or notches. The joists with the Metwood 2×10 Joist Reinforcer installed were tested with a 6-inch-diameter hole located at the Metwood 2×10 Joist Reinforcer in accordance with the manufacturer's instructions. Both bending and shear were investigated. The testing and analysis indicate no significant difference in maximum strength and modulus of elasticity of the joists tested.

- Standard specification for the sheet steel used for Metwood 2×10 Joist Reinforcer manufacture, by Metwood, Inc., containing minimum submittal, material and finish specifications for steel sheet to be used to manufacture the Metwood 2×10 Joist Reinforcer, consistent with this report.

PRODUCT IDENTIFICATION

- Metwood 2×10 Joist Reinforcer shall be marked at the plant with the identifying language "See ICC-ES Legacy Report No. 97-73."

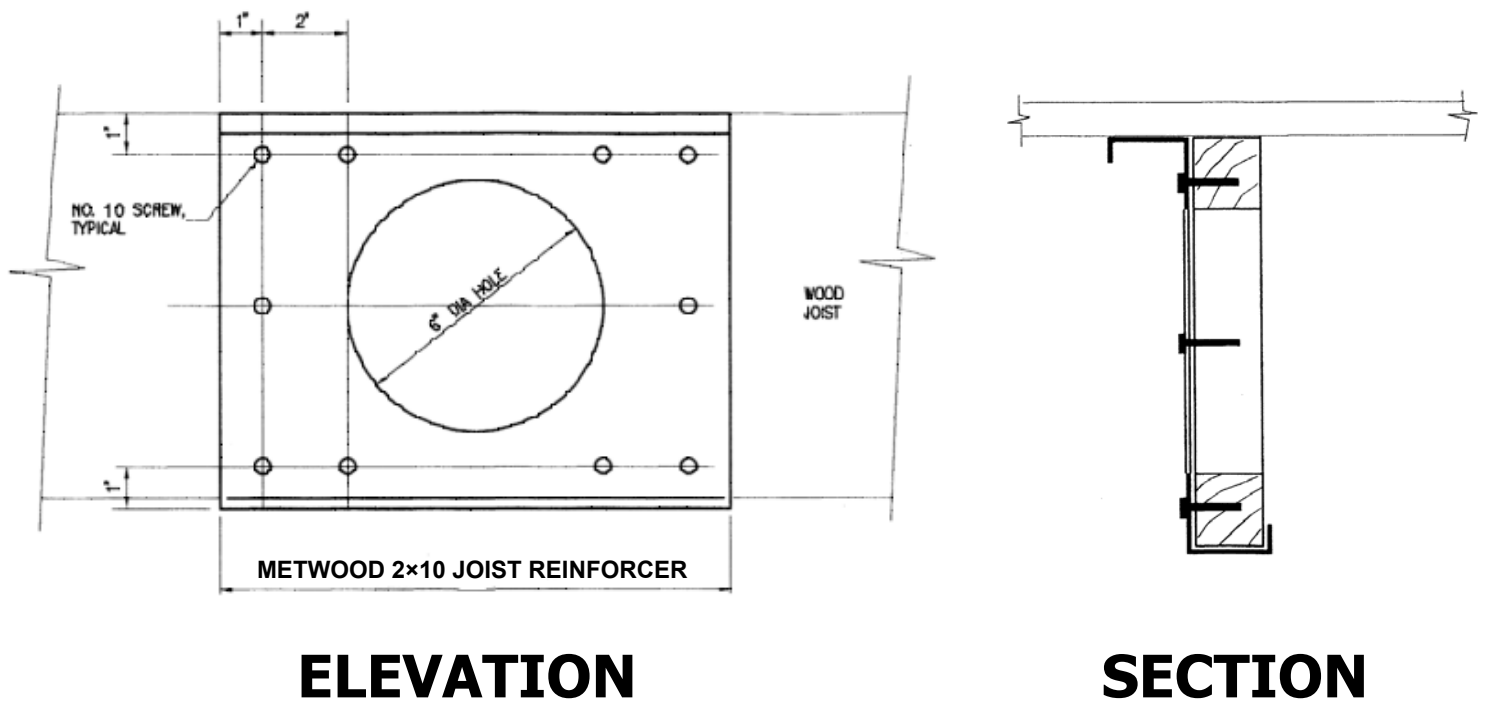

10 fasteners shall be used in the predrilled holes located as indicated above. The fasteners shall be 1¹/₄-inch-long (32 mm) No. 10 wood screws.

FIGURE 1*—METWOOD 2×10 JOIST REINFORCER

*THIS DRAWING IS FOR ILLUSTRATION PURPOSES ONLY. IT IS NOT INTENDED FOR USE AS A CONSTRUCTION DOCUMENT FOR THE PURPOSE OF DESIGN, FABRICATION OR ERECTION.